

<h1 style="margin: 0;">SPECIFICATION</h1> <p style="margin: 0;">MODEL : SPHWHTL3D305E6V0F5</p>
--

[Approved Rank : $V_F(E6)$, $CCT(V0)$, $Im_v(F5)$]

3535 Ceramic PKG



CUSTOMER :		
DRAWN	CHECKED	APPROVED

SAMSUNG LED		
DRAWN	CHECKED	APPROVED

SAMSUNG LED CO.,LTD.
 314, MAETAN3-DONG, YEONGTONG-GU,
 SUWON-City, GYEONGGI-DO, KOREA,443-743

Contents

1.	Product Outline	-----	3
2.	Absolute Maximum Rating	-----	3
3.	Characteristics	-----	3
4.	Typical Characteristics Graph	-----	6
5.	Outline Drawing & Dimension	-----	7
6.	Reliability Test Items & Conditions	-----	8
7.	Solder Conditions	-----	9
8.	Taping Dimension	-----	10
9.	Label Structure	-----	11
10.	Lot Number	-----	11
11.	Reel Packing Structure	-----	12
12.	Aluminium Packing Bag	-----	13
13.	Precaution For Use	-----	14
14.	Hazard Substance Analysis	-----	15
15.	Revision History	-----	18

1. Product Outline

- . Ceramic Package (3.5 x 3.5 x 1.89t mm)
- . Wide Viewing Angle ($\Delta\theta$: 125° x 125°) for uniform illuminance
- . InGaN/GaN MQW LED with Long-time Reliability
- . Lead (Pb) free product – RoHS compliant

2. Absolute Maximum Rating

- 1) Operation Forward Current ($T_a = 25^\circ\text{C}$) 1500 mA
- 2) Thermal Resistance ($R_{th,j-c}$) 6.1 $^\circ\text{C}/\text{W}$
- 3) LED Junction Temperature (T_J) 150 $^\circ\text{C}$
- 4) Operating Temperature Range (T_{opr}) -40 $^\circ\text{C}$ ~ 85 $^\circ\text{C}$
- 5) Storage Temperature Range (T_{stg}) -40 $^\circ\text{C}$ ~ 100 $^\circ\text{C}$

3. Characteristics

- 1) Electro-Optical characteristics

($T_a : 25^\circ\text{C}$)

CCT(K)	Item	Unit	Condition	Rank	Min	Typ	Max
3000K	Luminous Flux	lm	$I_F = 350 \text{ mA}$	F5	90	-	140
	Forward Voltage (V_F)	V		E6	2.7	-	3.3
	CRI			-	80	-	-
	Viewing Angle	$^\circ$	-	-	125 $^\circ$	-	
	Size	mm		3.5 x 3.5 x 1.89			

2) Chromaticity Diagram

 ($T_a : 25^{\circ}\text{C}$)

3) Chromaticity Coordinates

TABLE	Rank	CIE X	CIE Y	Rank	CIE X	CIE Y
3000K (V0)	V1	0.4147	0.3814	V5	0.4183	0.3898
		0.4183	0.3898		0.4221	0.3984
		0.4242	0.3919		0.4281	0.4006
		0.4203	0.3833		0.4242	0.3919
	V2	0.4203	0.3833	V6	0.4242	0.3919
		0.4242	0.3919		0.4281	0.4006
		0.4300	0.3939		0.4342	0.4028
		0.4259	0.3853		0.4300	0.3939
	V3	0.4259	0.3853	V7	0.4300	0.3939
		0.4300	0.3939		0.4342	0.4028
		0.4359	0.3960		0.4403	0.4049
		0.4316	0.3873		0.4359	0.3960
	V4	0.4316	0.3873	V8	0.4359	0.3960
		0.4359	0.3960		0.4403	0.4049
		0.4418	0.3981		0.4465	0.4071
		0.4373	0.3893		0.4418	0.3981

TABLE	Rank	CIE X	CIE Y	Rank	CIE X	CIE Y
3000K (V0)	V9	0.4221	0.3984	VD	0.4259	0.4073
		0.4259	0.4073		0.4299	0.4165
		0.4322	0.4096		0.4364	0.4188
		0.4281	0.4006		0.4322	0.4096
	VA	0.4281	0.4006	VE	0.4322	0.4096
		0.4322	0.4096		0.4364	0.4188
		0.4385	0.4119		0.4430	0.4212
		0.4342	0.4028		0.4385	0.4119
	VB	0.4342	0.4028	VF	0.4385	0.4119
		0.4385	0.4119		0.4430	0.4212
		0.4449	0.4141		0.4496	0.4236
		0.4403	0.4049		0.4449	0.4141
	VC	0.4403	0.4049	VG	0.4449	0.4141
		0.4449	0.4141		0.4496	0.4236
		0.4513	0.4164		0.4562	0.4260
		0.4465	0.4071		0.4513	0.4164

4) VF Rank

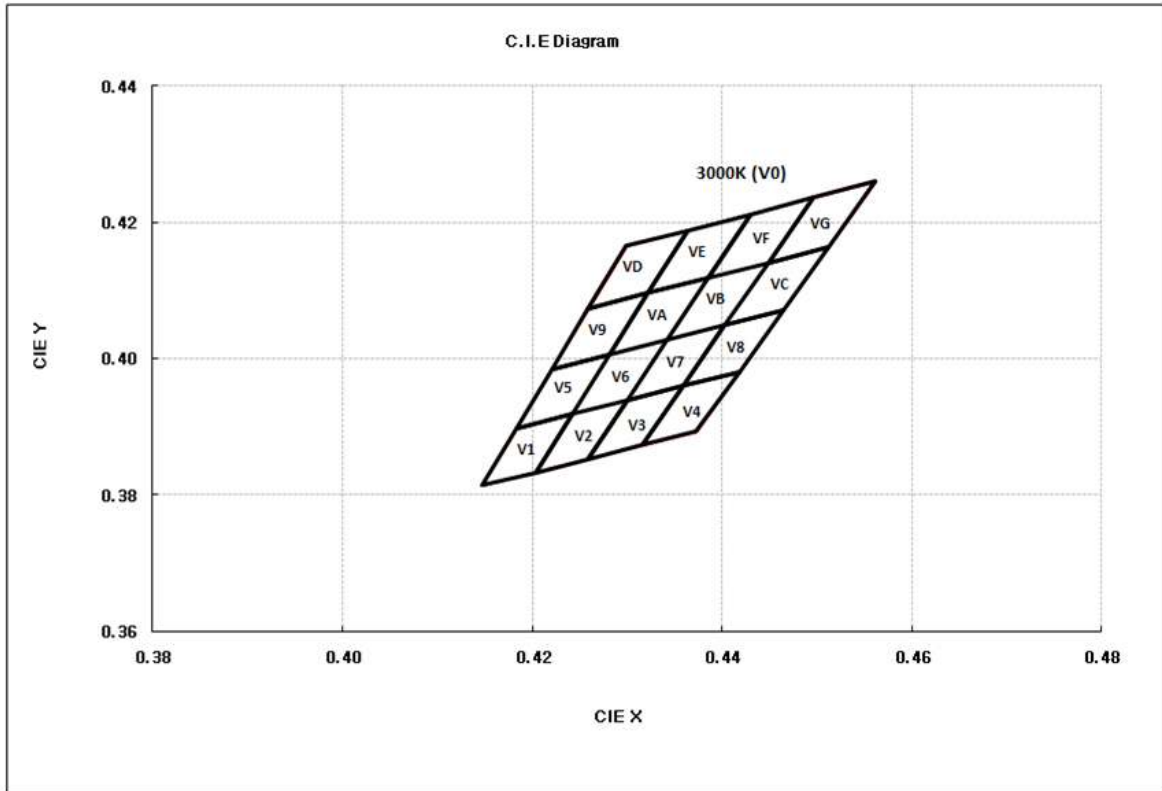
Parameter	Symbol	Condition	Rank	Rank	Min.	Typ.	Max.
Forward Voltage	V _F	I _F = 350mA	E6	E3	2.7	-	3.0
				H3	3.0	-	3.3

5) Luminous flux Rank

Parameter	Symbol	Condition	Rank	Rank	Min.	Typ.	Max.
Luminous Flux	Φ _V	I _F = 350mA	F5	F1	90	-	100
				G1	100	-	110
				H1	110	-	120
				J1	120	-	130
				K1	130	-	140

Notes:

- 1) Samsung LED has ±7% tolerance of flux measurements
- 2) Samsung LED has ±0.1V tolerance of forward voltage measurements
- 3) Samsung LED has ±3.0 tolerance of CRI measurements
- 4) Samsung LED has ±0.01 tolerance of CCx, CCy
- 5) Samsung LED has ±0.13mm tolerance on device dimensions.

4. Typical Characteristics Graph

($T_a = 25^\circ\text{C}$)

Normalized Flux vs. Forward Current

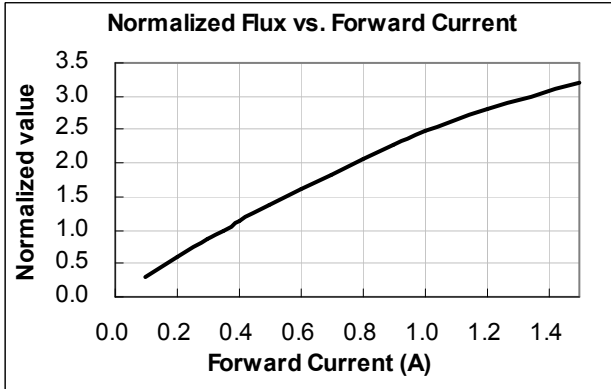

Forward Current vs. Forward Voltage

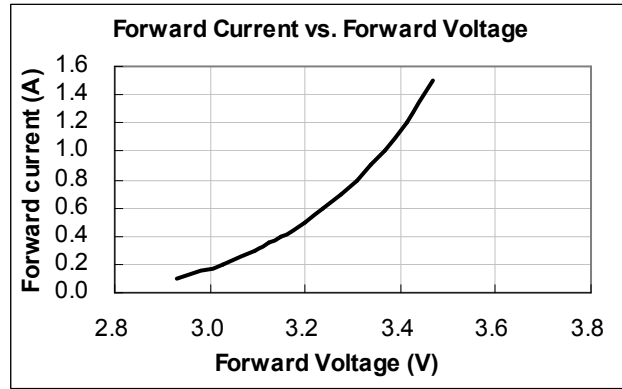

Normalized Flux vs. Junction Temp.

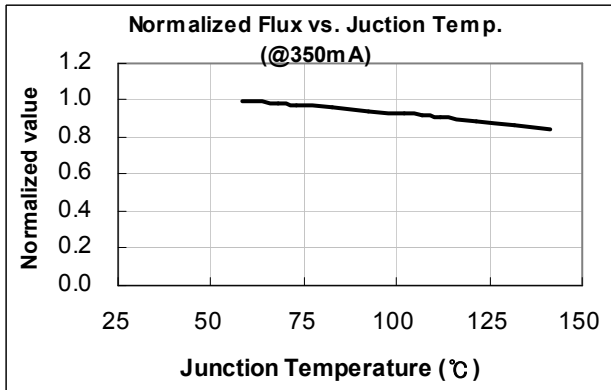

Substrate Temp. vs. Forward Voltage

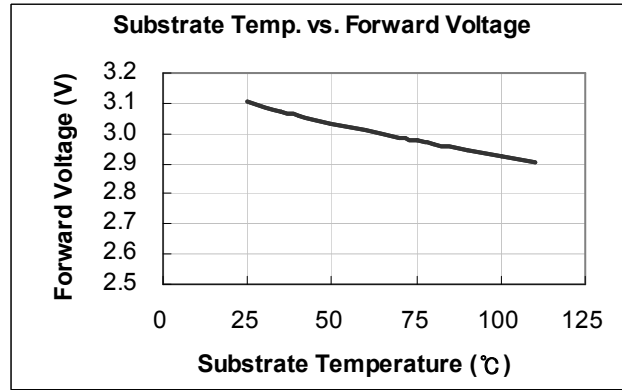

Spectrum Distribution

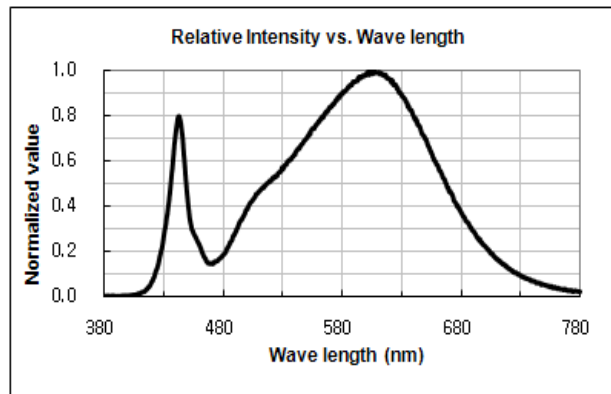

Derating Curve

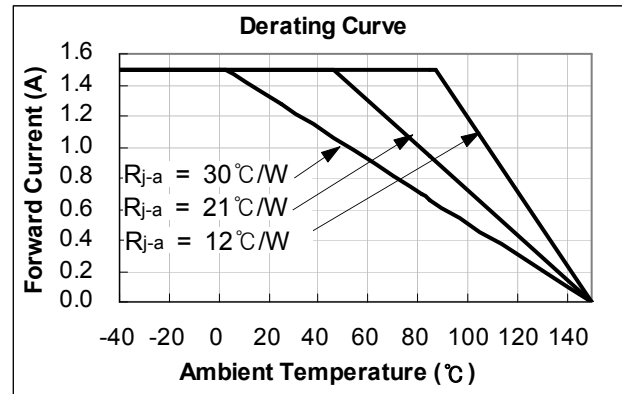

Forward Current vs. Color x,y

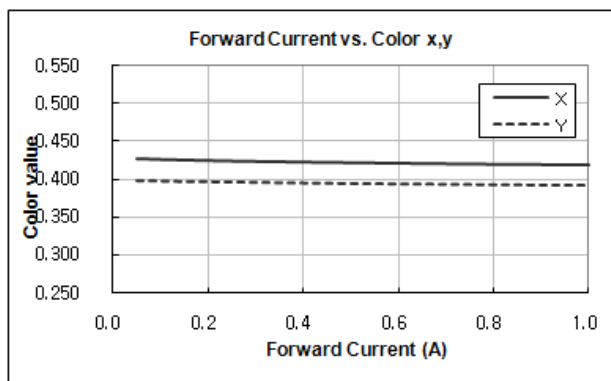

Viewing angle vs. Color Value

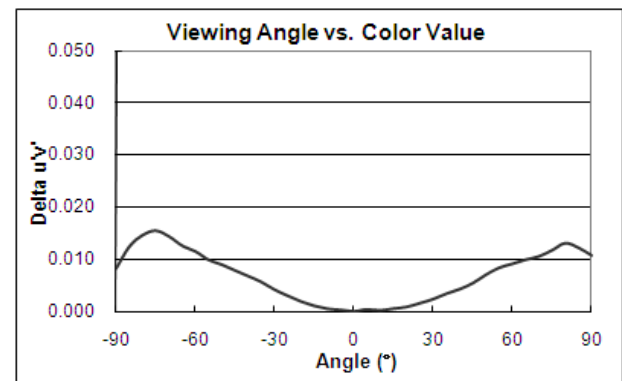

Viewing Angle

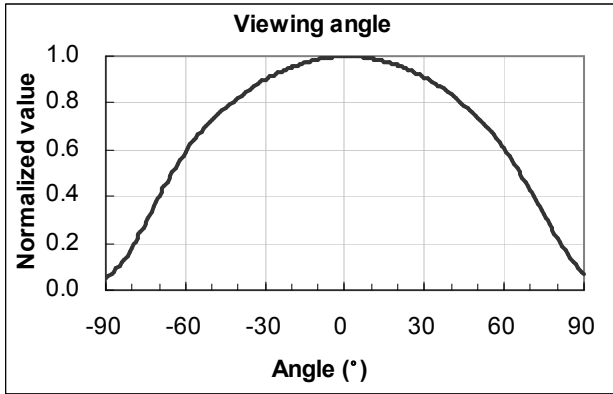

5. Outline Drawing & Dimension

unit : mm
Tolerance : ± 0.13

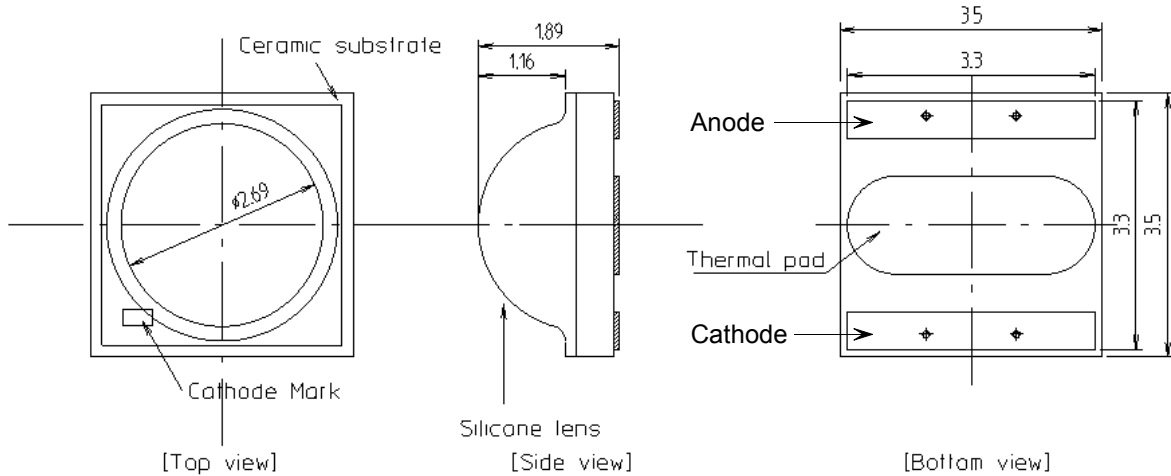

Recommended Land Pattern

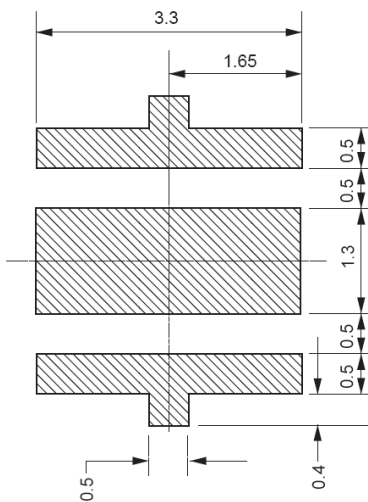

- * This LED has built-in ESD protection device(s) connected in parallel to LED Chip(s).
- * The thermal pad is electrically isolated from the anode and cathode contact pads.

6. Reliability Test Items and Conditions

1) Test Items and Results

Test Items	Test Conditions	Test Hours/Cycles
Room Temperature Life Test	25℃, DC 700 mA	1000 Hr
High Temperature humidity Life Test	85℃, 85%, DC 600 mA	1000 Hr
High Temperature Life Test	85℃, DC 600 mA	1000 Hr
Low Temperature Life Test	-40℃, DC 700 mA	1000 Hr
Temperature Humidity Cycle	-10℃ ↔ 25℃ 95%RH ↔ 85℃ 95%RH 350mA, 95%RH, 24hrs/1cycle	10 Cycles
Thermal Shock	-45 ℃/15 min ↔ 125 ℃/ 15 min. Temp.change within 5min.	200 Cycles
High Temperature Storage	Ta=120℃	1000 Hr
Low Temperature Storage	Ta=-40℃	1000 Hr
ESD(HBM)	R1=10MΩ, R2=1.5KΩ, C=100pF, V=±5KV, 5Times	5 Times (±5kV)

2) Criteria for Judging the Damage

Item	Symbol	Test Condition [T _a = 25℃]	Limit	
			Min.	Max.
Forward Voltage	V _F	350 mA	-	U.S.L. * 1.2
Luminous flux	Im	350 mA	L.S.L. * 0.7	-

* U.S.L. : Upper Standard Level L.S.L. : Lower Standard Level

7. Solder Conditions

1) Reflow Conditions (Pb Free)

Reflow Frequency : 2 times max.

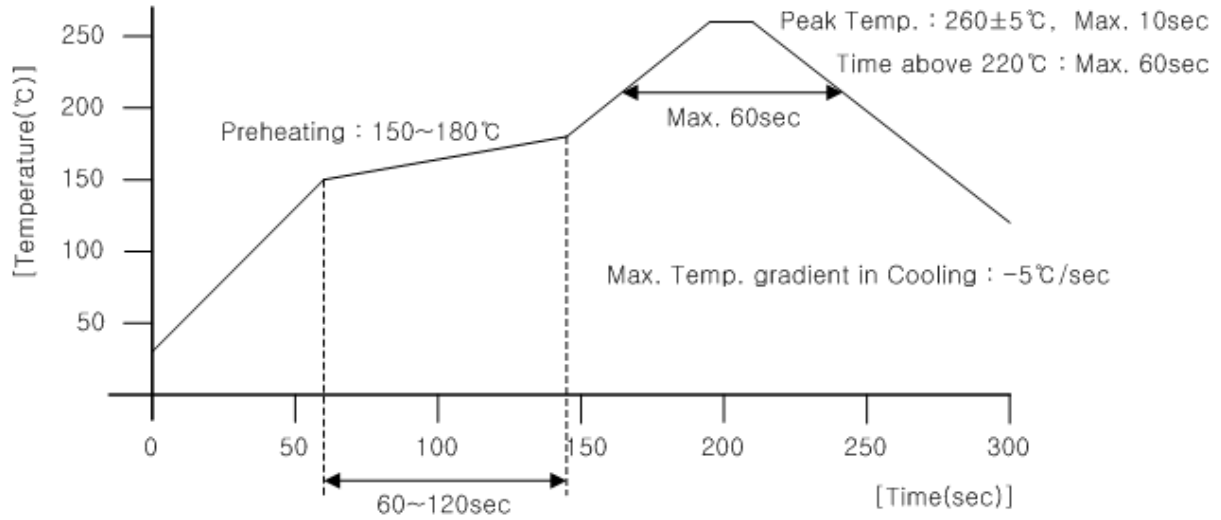

2) For Manual Soldering

Not more than 5 seconds @Max. 300°C, under soldering iron.

8. Taping Dimension

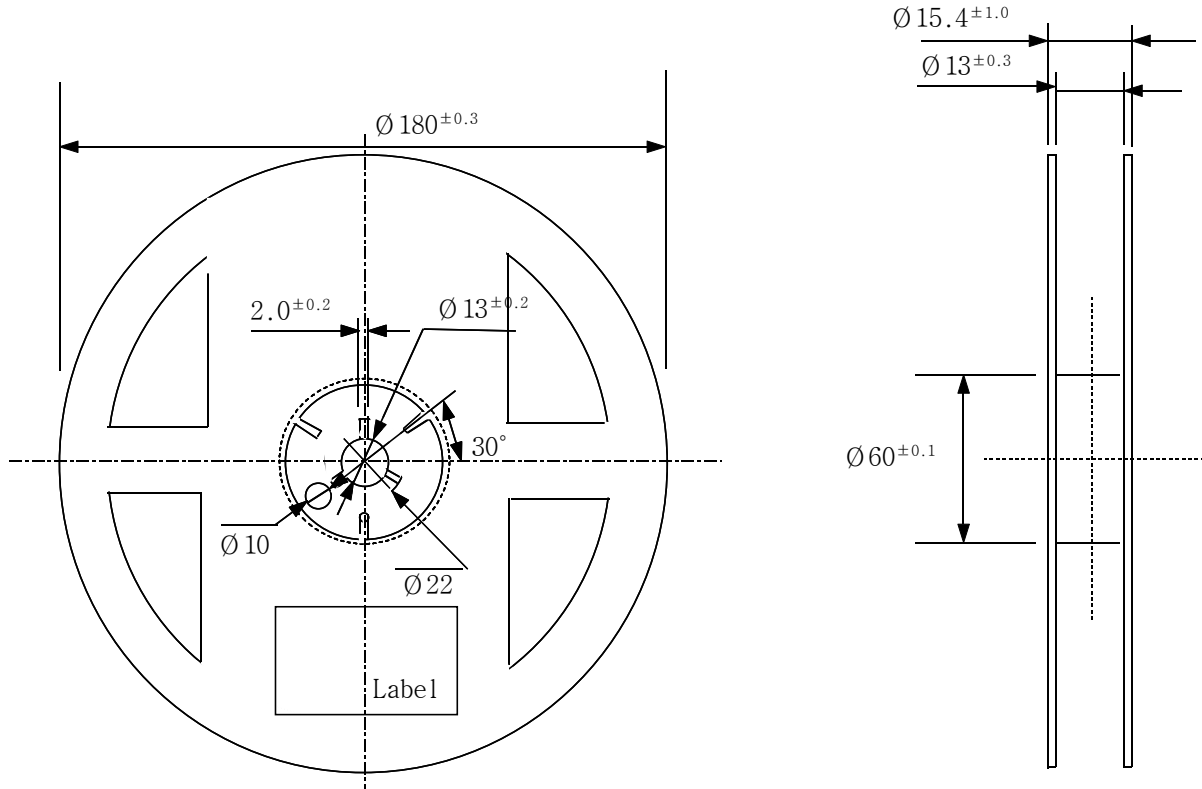
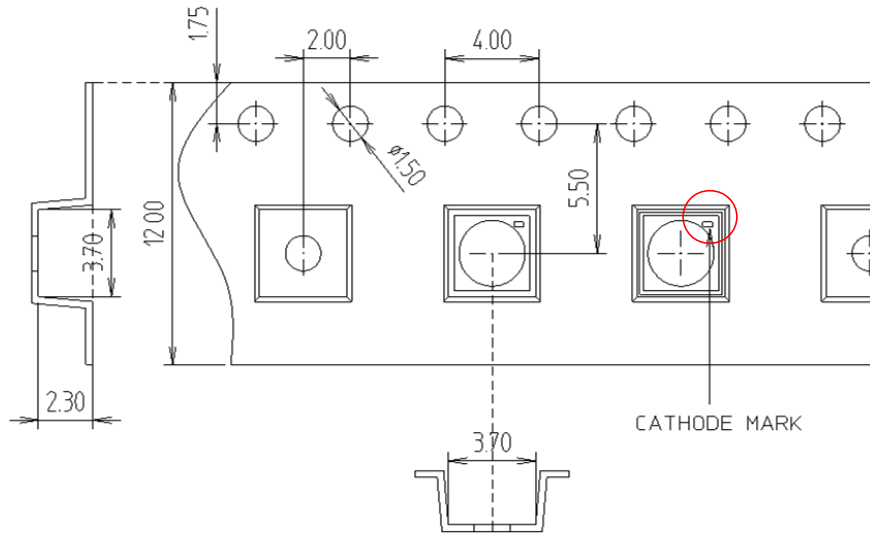

- (1) Quantity : The quantity/reel to be 1,000 pcs.
- (2) Cumulative Tolerance : Cumulative tolerance/10 pitches to be ± 0.2 mm
- (3) Adhesion Strength of Cover Tape : Adhesion strength to be 0.1-0.7N when the cover tape is turned off from the carrier tape at 10° angle to be the carrier tape.
- (4) Packaging : P/N, Manufacturing data code no. and quantity to be indicated on a damp proof package.

9. Label Structure

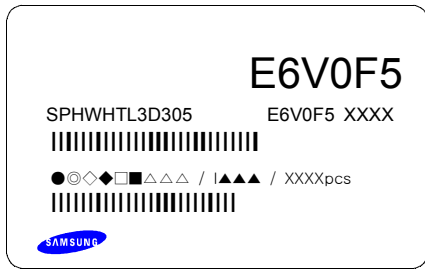

Rank Code

/E6/ : VF Rank (refer to page 5)

/V0/ : Chromaticity Coordinate Rank, CIE (refer to page 4)

/F5/ : Luminous Flux (refer to page 5)

10. Lot Number

The Lot number is composed of the following characters

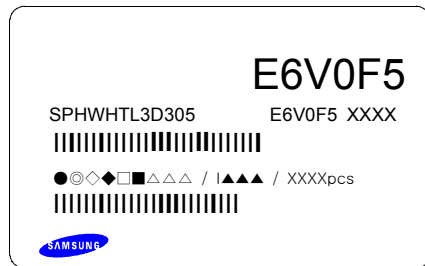

● ◎ ◇ ◆ □ ■ △ △ △ / | ▲ ▲ ▲ / 1000PCS

● : Production Site (S:SAMSUNG LED, G:Gosin China)

◎ : L (LED)

◇ : Product State (A:Normality, B:Bulk, C:First Production, R:Reproduction, S:Sample)

◆ : Year (S:2008, T:2009, U:2010...)

□ : Month (1 ~ 9, A, B)

■ : Day (1 ~ 9, A, B ~ V)

△ : SAMSUNG LED Product Number (1 ~ 999)

▲ : Reel Number (1 ~ 999)

11. Reel Packing Structure

Reel

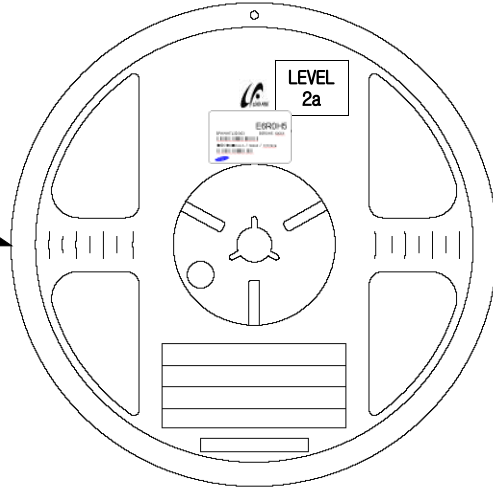
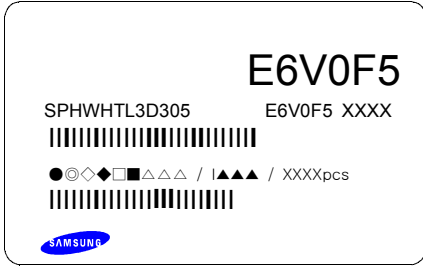

Aluminum Vinyl Bag

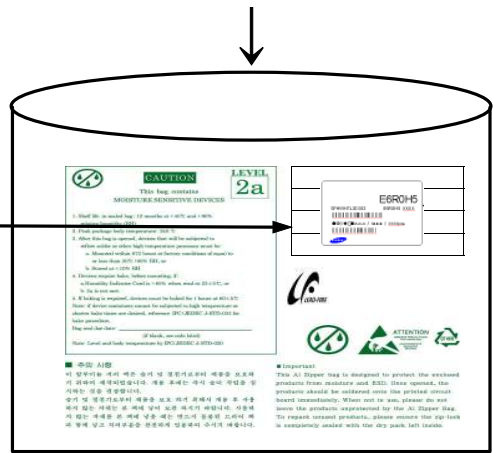
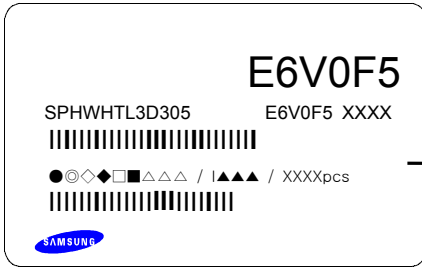

Material : Paper(SW3B(B))

TYPE	SIZE(mm)		
	a	b	c
7inch	250	225	190

① SIDE

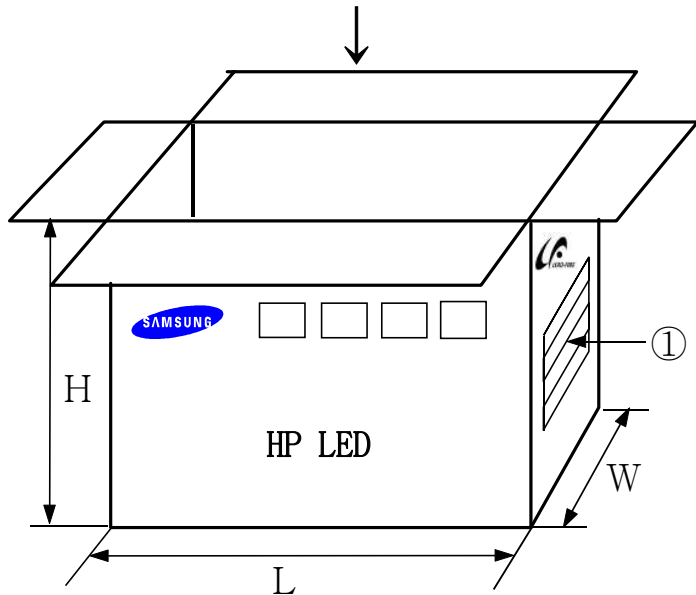
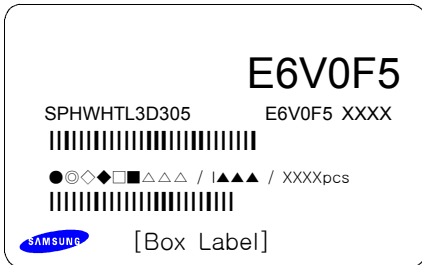

13. Precaution for use

- 1) For overcurrent-protection, customers are recommended to apply resistors connected in series with the LEDs to mitigate sudden change of the forward current caused by shift of the forward voltage.
- 2) This device should not be used in any type of fluid such as water, oil, organic solvent, etc. When cleaning is required, IPA is recommended as cleaning agent. Solvent-based cleaning agent such as Zestron^(R) may damage the silicone resins used in the device.
- 3) When the device is in operation, the forward current should be carefully determined considering the maximum ambient temperature and the corresponding junction temperature.
- 4) LEDs must be stored in a clean environment. If the LEDs are to be stored for 3 months or more after being shipped from Samsung LED, they should be packed with a nitrogen-filled container.
(Shelf life of sealed bags: 12 months, temp. 0~40°C, 20~70%RH)
- 5) After storage bag is open, device subject to soldering, solder reflow, or other high temperature processes must be:
 - a. Mounted within 168 hours (7 days) at an assembly line with a condition of no more than 30°C/60%RH.
 - b. Stored at <10% RH.
- 6) Repack unused Products with anti-moisture packing, fold to close any opening and then store in a dry place.
- 7) Devices require baking before mounting, if humidity card reading reaches 60% at 23±5°C.
- 8) Devices must be baked for 24hours at 65±5°C, if baking is required.
- 9) The LEDs are sensitive to the static electricity and surge current. It is recommended to use a wrist band or anti-electrostatic glove when handling the LEDs.
If voltage exceeding the absolute maximum rating is applied to LEDs, it may cause damage or even destruction to LED devices.
Damaged LEDs may show some unusual characteristics such as increase in leakage current, lowered turn-on voltage, or abnormal lighting of LEDs at low current.

14. Hazard Substance Analysis



Test Report No. F690501/LF-CTSAYAA11-02162

Issued Date: January 21, 2011

Page 1 of 5

To: SAMSUNG LED CO., LTD.
 314, Maetan-dong
 Yeongtong-gu
 Suwon-city
 GYEONGGI-DO 443-370
 Korea

The following merchandise was submitted and identified by the client as :

SGS File No. : AYAA11-02162
Product Name : 3535 Ceramic PKG
Item No./Part No. : N/A
Received Date : Jan 18, 2011
Test Period : Jan 19, 2011 to Jan 20, 2011
Test Performed : SGS Testing Korea tested the sample(s) selected by applicant with following results
Test Results : For further details, please refer to following page(s)
Comments : By the applicant's specific request, the sampling and testing was performed only for the part indicated in the photo without disassembly.

Timothy Jeon
 Jinhee Kim
 Cindy Park
 Jerry Jung/ Testing Person

SGS Testing Korea Co. Ltd.

Jeff Jang / Chemical Lab Mgr

This document is issued by the Company, SGS, in its Standard Conditions of Service printed on each report or request for analysis at www.sgs.com and, for electronic format documents, subject to Terms and Conditions for Electronic Documents at www.sgs.com/sgsweb/sgsweb.nsf.
 Signature is shown in the presence of publicly recognizable and authorized person named therein. Any misuse of this document is against the information submitted herein, unless the Company's Stamp at the time of its issuance and/or other an issue of Client's possession. It may. The Company's sole responsibility is to the Client and this document does not constitute grounds to a disclaimer from assuming all their rights and obligations under the transaction occurrence. This document cannot be reproduced, stored in full, without prior written approval of the Company. Any unauthorized alteration, copying or distribution of the content or occurrence of this document is strictly prohibited and may be prosecuted to the fullest extent of the law.
 Unless otherwise stated the results shown in this report refer only to the sample(s) tested and such sample(s) are retained for 30 days only.

F052 Version3

SGS Testing Korea Co., Ltd

322, The O valley, 555-0, Hoggae-dong, Dongseo-gu, Anyang-si, Gyeonggi-do, Korea 431-000
 t +82 (0)31 4628 025 f +82 (0)31 4608 098 http://www.sgsfab.co.kr www.kr.sgs.com/greenlab

Member of the SGS Group (Société Générale de Surveillance)



Test Report No. F690501/LF-CTSAYAA11-02162

Issued Date: January 21, 2011

Page 2 of 5

Sample No. : AYAA11-02162.001
Sample Description : 3535 Ceramic PKG
Item No./Part No. : N/A
Comments : Materials are Ceramic, Silicone.

Heavy Metals

Test Items	Unit	Test Method	MDL	Results
Cadmium (Cd)	mg/kg	With reference to IEC 62321:2008, ICP	0.5	N.D.
Lead (Pb)	mg/kg	With reference to IEC 62321:2008, ICP	5	N.D.
Mercury (Hg)	mg/kg	With reference to IEC 62321:2008, ICP	2	N.D.
Hexavalent Chromium (Cr VI)	mg/kg	With reference to IEC 62321:2008, UV-VIS	1	N.D.

Flame Retardants-PBBs/PBDEs

Test Items	Unit	Test Method	MDL	Results
Monobromobiphenyl	mg/kg	With reference to IEC 62321:2008, GC-MS	5	N.D.
Dibromobiphenyl	mg/kg	With reference to IEC 62321:2008, GC-MS	5	N.D.
Tribromobiphenyl	mg/kg	With reference to IEC 62321:2008, GC-MS	5	N.D.
Tetrabromobiphenyl	mg/kg	With reference to IEC 62321:2008, GC-MS	5	N.D.
Pentabromobiphenyl	mg/kg	With reference to IEC 62321:2008, GC-MS	5	N.D.
Hexabromobiphenyl	mg/kg	With reference to IEC 62321:2008, GC-MS	5	N.D.
Heptabromobiphenyl	mg/kg	With reference to IEC 62321:2008, GC-MS	5	N.D.
Octabromobiphenyl	mg/kg	With reference to IEC 62321:2008, GC-MS	5	N.D.
Nonabromobiphenyl	mg/kg	With reference to IEC 62321:2008, GC-MS	5	N.D.
Decabromobiphenyl	mg/kg	With reference to IEC 62321:2008, GC-MS	5	N.D.
Monobromodiphenyl ether	mg/kg	With reference to IEC 62321:2008, GC-MS	5	N.D.
Dibromodiphenyl ether	mg/kg	With reference to IEC 62321:2008, GC-MS	5	N.D.
Tribromodiphenyl ether	mg/kg	With reference to IEC 62321:2008, GC-MS	5	N.D.
Tetrabromodiphenyl ether	mg/kg	With reference to IEC 62321:2008, GC-MS	5	N.D.
Pentabromodiphenyl ether	mg/kg	With reference to IEC 62321:2008, GC-MS	5	N.D.
Hexabromodiphenyl ether	mg/kg	With reference to IEC 62321:2008, GC-MS	5	N.D.
Heptabromodiphenyl ether	mg/kg	With reference to IEC 62321:2008, GC-MS	5	N.D.
Octabromodiphenyl ether	mg/kg	With reference to IEC 62321:2008, GC-MS	5	N.D.
Nonabromodiphenyl ether	mg/kg	With reference to IEC 62321:2008, GC-MS	5	N.D.
Decabromodiphenyl ether	mg/kg	With reference to IEC 62321:2008, GC-MS	5	N.D.

NOTE: (1) N.D. = Not detected.(<MDL)
 (2) mg/kg = ppm
 (3) MDL = Method Detection Limit
 (4) - = No regulation
 (5) ** = Qualitative analysis (No Unit)
 (6) * = Boiling-water-extraction:
 Negative = Absence of CrVI coating
 Positive = Presence of CrVI coating; the detected concentration in boiling-water-extraction solution is equal or greater than 0.02 mg/kg with 50 cm2 sample surface area.

This document is issued by the Company subject to its General Conditions of Service posted on its website or issued or available at www.sgs.com and, for electronic format documents, subject to Terms and Conditions for Electronic Documents at www.sgs.com/sgs_electronic_documents.htm. Attention is drawn to the limitation of liability, indemnification and limitation of time stated therein. Any holder of this document is advised that information contained herein reflects the Company's findings at the time of its issuance only and under the terms of Client's instructions, if any. The Company's sole responsibility is to its Client and this document does not constitute either an assumption of liability or an obligation under the applicable documents. This document cannot be reproduced, stored in a retrieval system or otherwise disseminated without the prior written approval of the Company. Any unauthorized alteration, copying or distribution of the content or appearance of this document is strictly prohibited and may be prosecuted under applicable laws.



Test Report No. F690501/LF-CTSAYAA11-02162

Issued Date: January 21, 2011

Page 3 of 5

Sample No. : AYAA11-02162.001
Sample Description : 3535 Ceramic PKG
Item No./Part No. : N/A
Comments : Materials are Ceramic, Silicone.

Halogen Contents

Test Items	Unit	Test Method	MDL	Results
Bromine(Br)	mg/kg	BS EN 14582:2007 , IC	30	N.D.
Chlorine(Cl)	mg/kg	BS EN 14582:2007 , IC	30	N.D.
Fluorine(F)	mg/kg	BS EN 14582:2007 , IC	30	N.D.
Iodine(I)	mg/kg	BS EN 14582:2007 , IC	50	N.D.

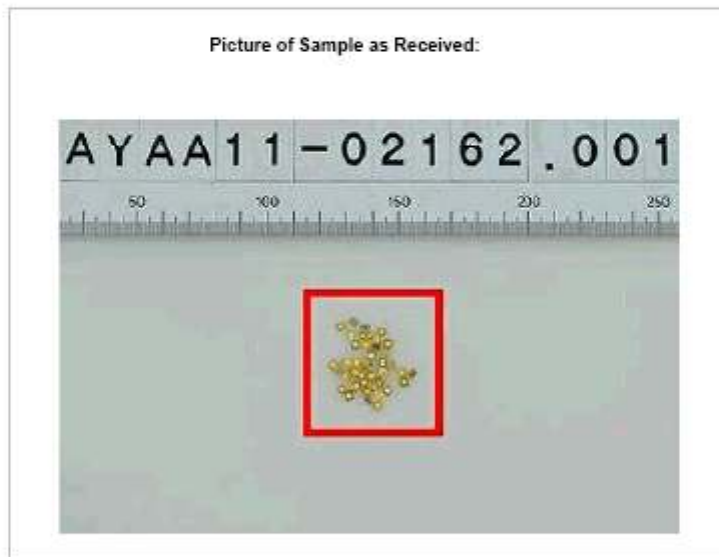

NOTE: (1) N.D. = Not detected.(<MDL)
 (2) mg/kg = ppm
 (3) MDL = Method Detection Limit
 (4) - = No regulation
 (5) ** = Qualitative analysis (No Unit)
 (6) * = Boiling-water-extraction:
 Negative = Absence of CrVI coating
 Positive = Presence of CrVI coating; the detected concentration in boiling-water-extraction solution is equal or greater than 0.02 mg/kg with 50 cm² sample surface area.

This document is issued by the Company which is its General Conditions of Service placed on order, available on request or accessible at www.samsungled.com and, for electronic format documents, subject to Terms and Conditions for Electronic Documents at www.samsungled.com. Attention is drawn to the limitation of liability, indemnification and arbitration clause defined therein. Any failure of this document is subject and information contained herein reflects the Company's findings at the time of its issuance only and while the field of Client's possession, if any. The Company's sole responsibility is to its Client and the documents does not constitute a contract or a warranty. Item numbers, all their rights and obligations under the Samsung documents. This document cannot be reproduced, except in full, without prior written approval of the Company. Any unauthorized alteration, forgery or falsification of the content or appearance of this document is strictly prohibited and may be prosecuted in the future. Samsung documents are available on the Internet only for the Client's personal and such handling are intended for 30 days only.

